

# Supplementary Sailing Instructions (SSI)

## YSS-Cup

Supplement to RRS Appendix S (Standard Sailing Instructions)

|                 |   |
|-----------------|---|
| <b>Dates</b>    | <b>13–14 June 2026</b>  |
| <b>Location</b> | Ystad Bay (Ystadbukten), Ystad  |
| <b>Classes</b>  | International 505 Class & 606 Class   |
| <b>OA</b>       | Ystad Segel Sällskap (Ystad SS)   |
| <b>NoR</b>      | <a href="https://www.sailarena.com/sv/se/club/yss/yss-cup-2026/">https://www.sailarena.com/sv/se/club/yss/yss-cup-2026/</a> |
| <b>ONB</b>      | <a href="https://www.sailarena.com/sv/se/club/yss/yss-cup-2026/">https://www.sailarena.com/sv/se/club/yss/yss-cup-2026/</a> |

**Preamble.** These Supplementary Sailing Instructions (SSI) supplement RRS Appendix S (*Standard Sailing Instructions*). Appendix S applies in full unless modified herein. In the event of conflict, these SI prevail. Rule changes stated in the Notice of Race (NoR) also apply.

**Notation.** The notation **[NP]** denotes a rule that shall not be grounds for protests by a boat. This changes RRS 60.1. The notation **(DP)** denotes a rule for which the penalty is at the discretion of the protest committee.

### 1. Rules

---

**1.1** The event is governed by the Racing Rules of Sailing (RRS), the rules in RRS Appendix S (*Standard Sailing Instructions*), these supplementary Sailing Instructions, and the Notice of Race.

**1.2** The following rule modifications stated in the NoR apply to all races:

- **NoR 1.5** – RRS 88.2 (*National Prescriptions*), prescriptions of the Swedish Sailing Federation (SSF) apply.
- **NoR 1.6** – RRS 44.1/44.2, One-Turn Penalty applies.
- **NoR 9.1** – RRS Appendix P with P2.3 not used and P2.2 extended to 'second and following times'.
- **NoR 10.1** – RRS Appendix A, Low Point System (A4).
- **NoR 10.2** – RRS 90.3(e) applies.
- **NoR 10.3** – RRS A2.1 modified: with three or fewer races completed no score is excluded; after more than three races one score is excluded.

### 2. Notices to Competitors

---

**2.1** The Official Notice Board (ONB) is located at: <https://www.sailarena.com/sv/se/club/yss/yss-cup-2026/>

### 3. Changes to Sailing Instructions

---

**3.1** Any change to the sailing instructions will be posted on the ONB before 08:00 on the day it takes effect.

**3.2** Any change to the schedule of races will be posted by 20:00 on the day before it takes effect.

### 4. Signals Made Ashore

---

**4.1** Signals made ashore will be displayed from the flagpole at the Ystad SS clubhouse.

**4.2** When flag **AP** is displayed ashore, '1 minute' is replaced with 'not less than 60 minutes' in RRS Race Signals.

## 5. Schedule of Races

---

5.1 The schedule of races is published in the Notice of Race, Section 6. Any changes will be posted on the Official Notice Board.

## 6. Class Flags

---

6.1 The class flag for the International 505 class is code flag F. The class flag for the 606 class is code flag E.

## 7. Racing Area

---

7.1 The racing area is as described in the Notice of Race, Section 8.

7.2 One starting vessel and one race area will be used for both classes.

## 8. The Courses and Marks

---

### 8A – International 505 Class

8.1 The 505 course is a windward/leeward course to be sailed:

Start – Mark 1 – Mark 2 – Marks 3s/3b – Mark 1 – Mark 2 – Mark 3b – Finish

8.2 The rounding marks are yellow cylinders. Mark 1 and Mark 2 are to be left to port.

8.3 When signal flag 3 is shown together with the Preparatory signal, the course will be three turns:

Start – Mark 1 – Mark 2 – Marks 3s/3b – Mark 1 – Mark 2 – Marks 3s/3b – Mark 1 – Mark 2 – Mark 3b – Finish

8.4 See Annex A for the 505 course diagram.

### 8B – 606 Class

8.5 The 606 course is a windward/leeward course to be sailed:

Start – Mark 1 – Mark 2 – Mark 1 – Mark 2 – Finish

8.6 The rounding marks are yellow tetrahedrons. Mark 1 and Mark 2 are to be left to port. Mark 2 is the last mark of the course: on the final downwind leg a boat shall round Mark 2 before finishing. A boat that crosses the finishing line without having rounded Mark 2 on that leg has not sailed the course.

8.7 When signal flag 3 is shown together with the Preparatory signal, the course will be three turns:

Start – Mark 1 – Mark 2 – Mark 1 – Mark 2 – Mark 1 – Mark 2 – Finish

8.8 See Annex B for the 606 course diagram.

8.9 The race committee will try to set the course so that a race will take approximately **40 minutes** for the first boat to finish.

## 9. The Start

---

9.0 **Two-class operation.** The 505 class and 606 class race on the same race area but use different starting procedures and separate courses.

### 9A – International 505 Class (Gate Start)

9.1 Races for the 505 class will be started using a gate start procedure under RRS 26.

9.2 The race committee signal vessel will be in the starting area, which will be to leeward of the course.

9.3 To alert boats that a race will begin soon, the race committee signal vessel will display an **orange flag** and **flag G**, with one sound signal, at least five minutes before the warning signal is displayed.

- 9.4** Prior to the warning signal, the race committee signal vessel will display the time between the starting signal and the time at which the gate boat will stop at the starboard end of the starting line. The default gate time is 3 minutes unless another time is displayed no later than the warning signal.
- 9.5 Pathfinder selection.** The race committee will appoint a pathfinder and a reserve pathfinder for each race. For the first race of the regatta the pathfinder is the boat that finished 3rd at SWE 505 Cup 1 (Saltsjöbadsregattan 2026), and the reserve is the boat that finished 4th. For subsequent races the pathfinder is the boat that finished in the previous race and the reserve the boat that finished 4th. If an appointed boat is not entered, not on the water, or has already been pathfinder during the regatta, the next-placed boat will be used.
- 9.6** The sail numbers of the pathfinder and reserve for the first race of each day will be posted on the ONB and displayed on the race committee signal vessel before flag G is displayed. For subsequent races on the same day, the numbers will be displayed on the race committee signal vessel before flag G is displayed for each race.
- 9.7** The pathfinder and reserve shall report to the gate boat (displaying flag G, near the race committee signal vessel) before the warning signal and shall follow the race committee's instructions. A pathfinder or reserve that fails to report will be scored DNS. This changes RRS A5.1 and A5.2.
- 9.8 [NP]** The starting line (except for the pathfinder) is between the port limit mark and the centre of the stern of the gate boat, which displays flag G.
- 9.9 [NP]** As close as possible to the starting signal (not before it, and within 10 seconds after it), the pathfinder shall pass the port limit mark sailing a close-hauled course on port tack. The gate boat will keep station close astern and slightly to leeward of the pathfinder. The starting line is open and boats may start once the gate boat has cleared the port limit mark, regardless of the starting signal. There will be no individual recall; RRS 29.1 does not apply.
- 9.10 [NP]** The pathfinder shall sail her close-hauled course until released by a sound signal from the gate boat, after which she may continue or tack. She ceases to be a starting mark when she tacks or when the gate has been open for the time signalled, whichever is first.
- 9.11** After the pathfinder is released, the gate boat will maintain her course and speed until the gate has been open for the time signalled. She will then stop and make one long sound signal, and the close of the gate will be signalled by lowering flag G on the gate boat with one short sound signal.
- 9.12 [NP]** All boats (except the pathfinder) shall start by crossing the starting line on starboard tack, after the starting signal and before the gate closes.
- 9.13 [NP]** A boat that has not already started correctly and is on the course side of the gate boat while the gate is open shall not cross the starting line from the course side.
- 9.14** A boat that has not started at the close of the gate will be scored DNS without a hearing. This changes RRS A5.1 and A5.2.
- 9.15** A boat that touches the gate boat shall take a One-Turn Penalty under RRS 44.2. However, if the contact causes the gate boat to alter course or speed, or causes the start to be abandoned, the boat will be disqualified without a hearing.
- 9.16 [NP]** From the preparatory signal until the pathfinder and gate boat cease to be starting marks, a boat shall not cause the pathfinder or gate boat to alter course or speed, shall not touch the pathfinder, and shall not pass or attempt to pass between the pathfinder and the gate boat.
- 9.17** The race committee may abandon a start if a significant wind shift or interference with the pathfinder or gate boat gives some boats a substantial advantage or disadvantage. Such an abandonment will not be grounds for redress. This changes RRS 61.4(b).

## 9B – 606 Class (Line Start)

- 9.18** For the 606 class a line start will be used. Races will be started using RRS 26.
- 9.19** To alert boats that a new starting sequence will begin soon, the orange starting line flag will be displayed six minutes before a warning signal is made.
- 9.20** A boat that does not start within five minutes after her starting signal will be scored Did Not Start (DNS). This changes RRS A5.1 and A5.2.

## 10. The Finish

**10.1** The finishing line is between a staff displaying a blue flag on the race committee vessel and the course side of the finishing mark.

## 11. Time Limits and Target Times

---

**11.1** The target time for the first boat to finish is approximately 40 minutes. Failure to meet the target time will not be grounds for redress. This changes RRS 61.4(b).

**11.2** The time limit for the first boat to sail the course is 90 minutes. If no boat finishes within this time, the race shall be abandoned.

**11.3** A boat that does not finish within 20 minutes after the first boat has finished will be scored Did Not Finish (DNF). This changes RRS 35, A5.1 and A5.2.

## 12. Hearing Requests

---

**12.1** The protest time limit is 45 minutes after the last boat finishes the last race of the day or the race committee signals no more racing today, whichever is later. This changes RRS Appendix S, S13.2.

## 13. Scoring

---

**13.1** Scoring follows NoR Section 10. The Low Point System (RRS Appendix A4) applies.

## 14. Safety

---

**14.1** The personal flotation device and cold-water clothing requirements in **NoR 1.3 and 1.4** apply at all times when afloat. **(DP)**

**14.2** A boat that retires from a race shall, as soon as possible, notify the race committee in person at the Race Office or at the finish area. **(DP)**

## 15. Prize Giving

---

**15.1** Prize giving will be held as soon as possible after results are confirmed (after the protest time limit has expired) on Sunday 14 June 2026 at the Ystad SS clubhouse.

**15.2** Prizes will be awarded in accordance with NoR Section 11.

## Annex A – 505 Class Course Diagram

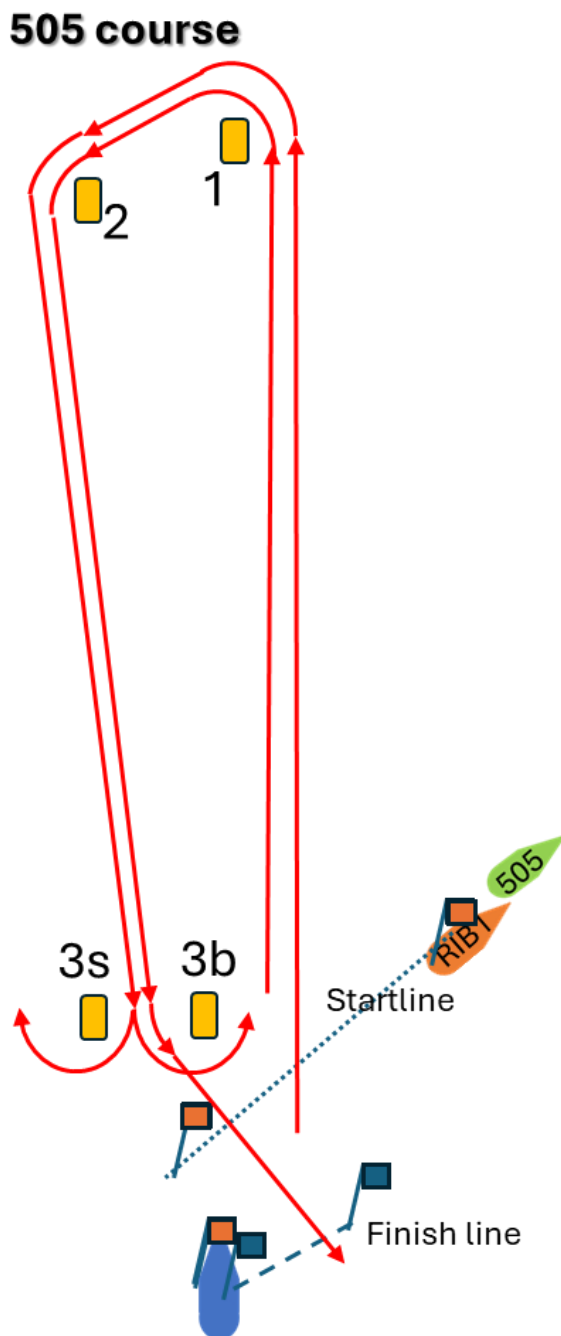

Course diagram for the 505 class. Yellow cylinder marks. M1 and M2 left to port; gate 3s/3b at the leeward end; finish line below the gate area.

## Annex B – 606 Class Course Diagram

## 606 course

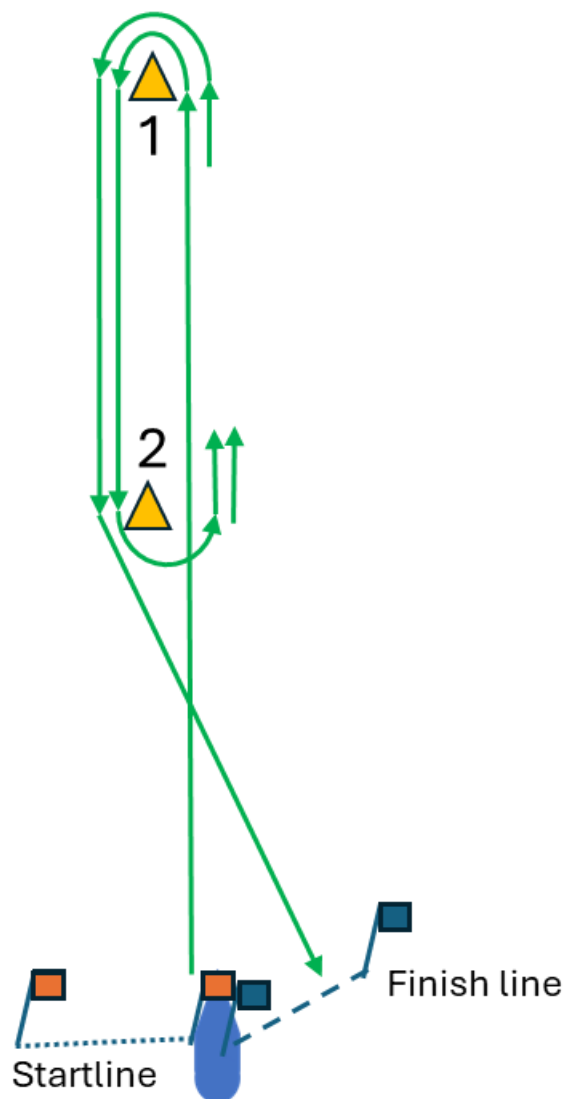

Course diagram for the 606 class. Yellow tetrahedron marks. M1 and M2 left to port; line start at lower left; finish line at lower right.

### Change Log

**v2.0 2026-06-01** First published version.